



FPH

FAN ASSISTED PTC HEATERS



Features	Unit	FPH1200	FPH1201	FPH1500	FPH1501	FPH2000	FPH2001
Heating Capacity	W	1200	1200	1500	1500	2000	2000
Power supply	V/Hz	230/50-60	115/50-60	230/50-60	115/50-60	230/50-60	115/50-60
Heating element type	-	PTC resistor, self regulating					
Thermal protection	-	Thermal cut out in case of fan failure (auto-reset for 100,000 cycles)					
Casing	-	Plastic according to UL94 V-0, black					
Axial fan	-	Ball bearing, service life 50.000 hrs at 25°C (77°F), air flow rate 160 m3/h, free flow					
Control operation	-	optional					
Electrical connections	-	3 screw terminals for stranded or rigid wire 2.5 mm ²					
Alarm output	-	optional 2 screw terminals for alarm signal 5-30V DC / 0,5A					
Protection class IEC	-	Class I, earthed					
Protection degree EN60529	-	IP20					
Operating temperature	°C (°F)	-40/+70 (-13/+158)					
Storage temperature	°C (°F)	-45/+80 (-49/+176)					
Mounting	-	Screw fixing (M4)					
Installation position	-	Best performance with horizontal installation					
Dimensions HxWxD	mm	95x160x120					
Weight (with packaging)	kg	1.20(1.27)					
Conformity	-	CE					

Versions

without bimetallic thermostat	FPH1200.00	FPH1201.00	FPH1500.00	FPH1501.00	FPH2000.00	FPH2001.00
with bimetallic thermostat integrated	FPH1200.01	-	FPH1500.01	-	-	-
with electronic board integrated	FPH1200.02	-	FPH1500.02	-	FPH2000.02	-

Functions of electronic board

1. electronic temperature control
2. green LED on for proper operation, red LED on for malfunction
3. 2 screw terminals for alarm signal 5-30V DC / 0,5A

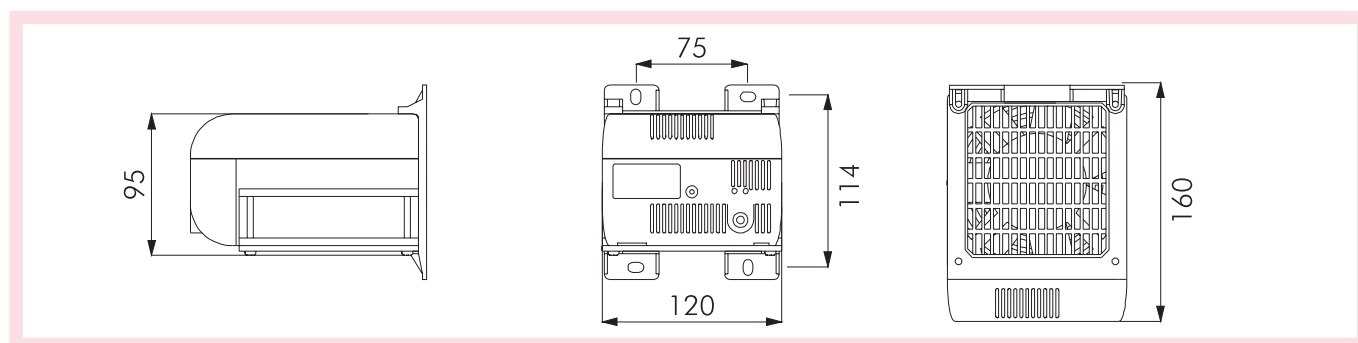

ael-cat-ent-15_01 - Specifications, values and drawings are subject to change without notice.